

## Tech Notes 44B - Wall Ties for Brick Masonry

[Revised May 2003]

**Abstract:** The use of metal ties in brick masonry dates back to loadbearing masonry walls in the 1850's. Historically, the size, spacing and type of ties have been entirely empirical. Over time, ties of various sizes, configurations and adjustability have been developed for loadbearing masonry, cavity walls and brick veneer construction. These ties are used to connect multiple wythes of masonry, often of different materials; anchor masonry veneer to backing systems other than masonry; and connect composite masonry walls. This *Technical Notes* addresses the selection, specification and installation of wall tie systems for use in brick masonry construction. Information and recommendations are included which address tie configuration, detailing, specifications, structural performance and corrosion resistance.

**Key Words:** anchors, brick, cavity walls, corrosion, design, differential movement, fasteners, grout, masonry, structural masonry, ties, veneer, walls.

### INTRODUCTION

This *Technical Notes* is the third in a series that addresses anchor bolts, fasteners and wall ties for brick masonry. This *Technical Notes* discusses wall ties commonly used in brick construction, their function, selection, specification and installation. The term "wall tie", as used in this *Technical Notes*, refers to wire or sheet metal devices used to connect two or more masonry wythes or used to connect masonry veneers to a structural backing system. The later of these are more properly identified as veneer anchors.

### GENERAL

The first use of wall ties in brick masonry construction can be traced to England in the mid-nineteenth century, where wrought iron ties were used in brick masonry cavity walls. Use of wall ties in the United States grew after testing showed that metal-tied walls were more resistant to water penetration than were masonry-bonded walls. Bonders, or "headers", used in masonry-bonded walls may provide direct paths for possible water penetration. Testing also indicated that the compressive strength of metal-tied cavity walls and solid walls, and the transverse strength of metal-tied solid walls were comparable to those of masonry-bonded walls.

The use of wall ties has continued to increase over the years due to a trend away from massive, multi-wythe masonry walls to relatively thin masonry cavity walls, double-wythe walls and veneers. The use of backing systems other than masonry, i.e., steel, concrete and wood, has rendered bonding with masonry headers impossible, leading to the development of a number of different metal tie systems. Investigation into the performance of masonry-bonded walls in which the bonded wythes are of different materials indicates frequent shear failures in the headers.

During this period of transition, little progress was made in the area of rational design of wall tie systems. Typically, the sizing and spacing of wall ties has been based largely on empirical information and the designer's judgment. Questions concerning strength, stiffness, corrosion and the effects of these on the long-term performance of wall ties, have been posed. Selection of a tie system to function properly under these conditions is further complicated by the vast number of tie types available and the variety of materials from which they are fabricated. Most tie systems perform well for their intended application. Some tie systems, however, are poorly designed and do not provide adequate load transfer for brick masonry. The distinction is often subtle and requires an understanding of the properties and characteristics of brick masonry. With the addition of Chapter 6 on Veneers to the Building Code Requirements for Masonry Structures (ACI 530 / ASCE 5 / TMS 402-02), the empirical requirements for type, size and spacing of metal ties have been reviewed and refined. This Code, known as the MSJC Code, contains requirements for most types of tie systems.

### Function of Wall Ties

Typically, wall ties perform three primary functions between a wythe of brick and its backing or another wythe of masonry: 1) provide a connection, 2) transfer lateral loads, 3) permit in-plane movement to accommodate differential movements and, in some cases, restrain differential movement. In addition to these primary functions, metal ties (as joint reinforcement) may also be required to serve as horizontal structural reinforcement or provide longitudinal continuity.

For a tie system to fulfill these functions, it must: 1) be securely attached to both masonry wythes or the brick veneer and its backing, 2) have sufficient stiffness to transfer lateral loads with minimal deformations, 3) have a minimum amount of

mechanical play, 4) be corrosion-resistant and 5) be easily installed to reduce installation errors and damage to the tie system. This listing is far from complete; special project conditions, unusual details and special building code requirements must also be considered. Availability and cost are always factors in product specifications. However, cost should not have a major influence on the selection of a wall tie system since the cost of ties is typically a very small part of the total wall cost.

## TYPES OF WALL TIES

### General

There are a number of different wall tie systems available for brick masonry wall systems. These include unit ties, continuous horizontal joint reinforcement, adjustable ties (unit and continuous) and re-anchoring systems. Placement requirements for ties are shown in Figure 1.

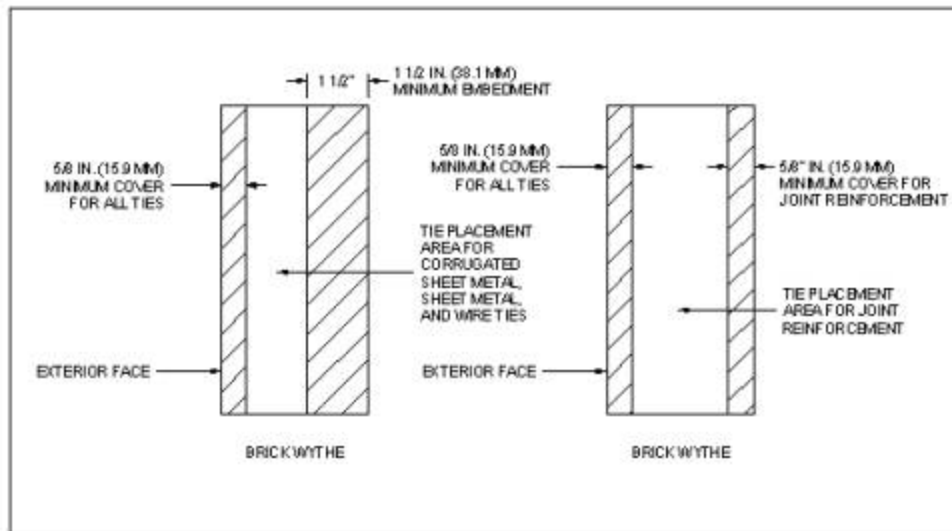
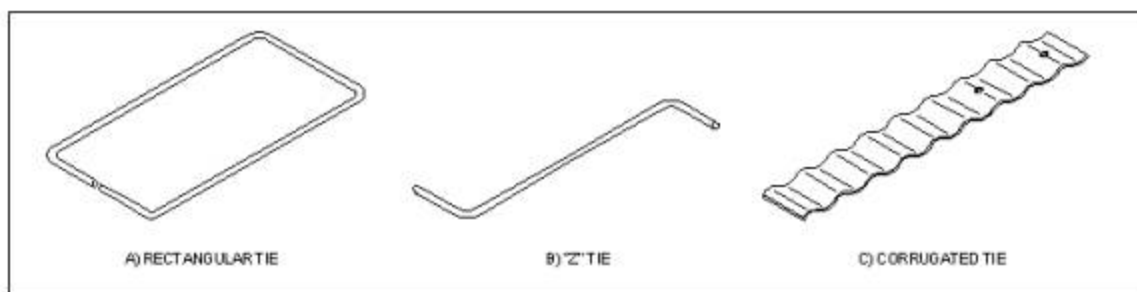

FIG. 1

### Unit Ties

Unit ties are rectangular "box" ties, "Z" ties and corrugated ties, as shown in Figure 2. Rectangular and "Z" ties are usually fabricated from cold-drawn steel wire conforming to ASTM A 82. Rectangular and "Z" ties made of stainless steel conforming to ASTM A 580 are also available for use in more corrosive environments. Corrugated sheet steel ties are typically manufactured from steel sheet conforming to ASTM A 1008 and are also available in stainless steel conforming to A 240.



Unit Ties

FIG. 2

Rectangular and "Z" ties are used to bond walls constructed of two or more masonry wythes. "Z" ties should only be used to bond walls constructed with solid units (not less than 75% solid) or grouted units. Rectangular ties may be used with either solid or hollow units. Such wire ties should not have a bend or drip to reduce water transfer. Such a bend in the tie reduces the capacity of the tie to transfer lateral load.

Corrugated ties are typically used in low-rise, residential veneer over wood frame construction and are not recommended for construction incorporating brick veneer over steel studs, masonry-backed cavity walls, multi-wythe walls or grouted masonry walls.

Typical installation details are shown in Fig. 3.

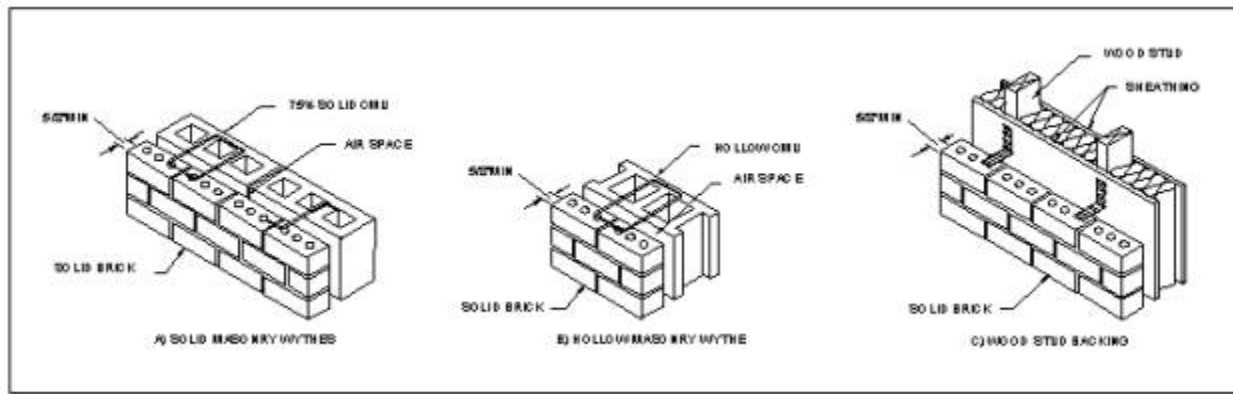

Unit Tie Placement Details  
FIG. 3

### Joint Reinforcement

Continuous horizontal joint reinforcement is typically made from #8, 9, 10, or 11 gage wire, or 3/16 in. (5 mm) diameter wire, conforming to ASTM A 951, in lengths of 10 to 12 ft (3 to 4 m). The most common configurations are the ladder, truss, and tab types (see Fig. 4).

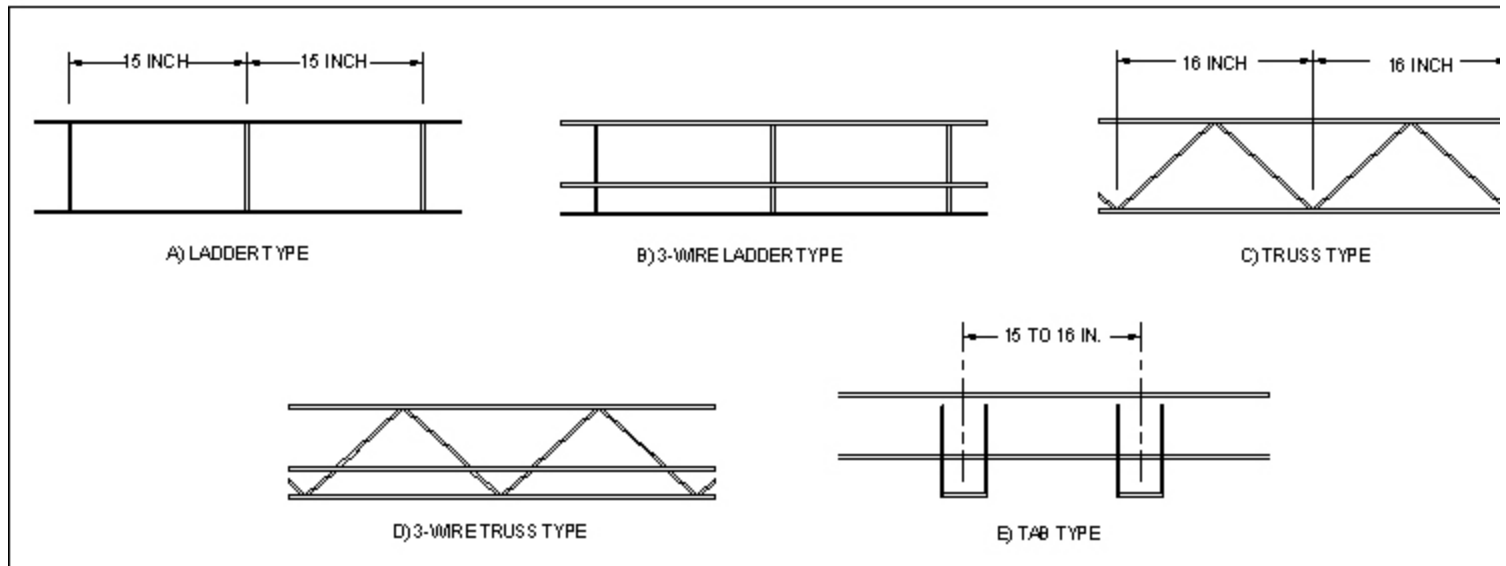

Continuous Joint Reinforcement  
FIG. 4

Structural testing performed in the early 1960's indicated that multi-wythe walls tied with joint reinforcement performed as well as walls tied with unit ties or masonry bonders. Joint reinforcement may be used in multi-wythe solid walls, masonry cavity walls, brick veneer with masonry backing, and grouted masonry walls (see Fig. 5). As with wire ties, the cross wires should be without drips.

Truss-type joint reinforcement is not recommended for use in cavity walls or brick veneer with masonry backing. Test results also indicated that truss-type joint reinforcement, in such wall systems, did not contribute to any composite action in the vertical span, but did develop a degree of composite action in the horizontal span. The configuration of the truss diagonals can restrain differential movement between wythes and possibly result in bowing of the walls.

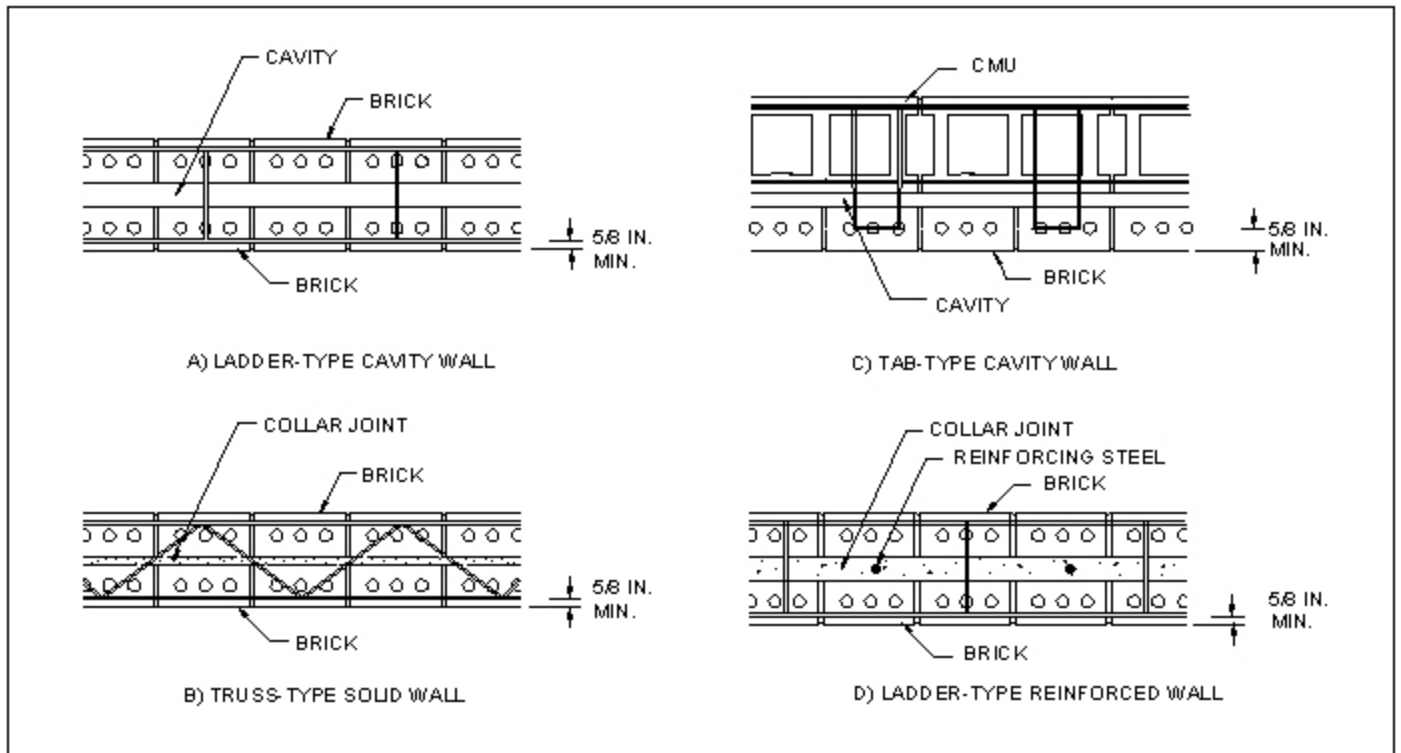

Joint Reinforcement Details  
FIG. 5

### Adjustable Ties

Adjustable tie systems were initially developed to accommodate the use of face brick whose bed joints did not align vertically with interior masonry wythes. This concept has been extended to ties used to attach brick to other systems, resulting in the use of both adjustable unit ties and adjustable ties with joint reinforcement.

The use of adjustable ties has increased rapidly for a number of reasons: 1) Adjustable ties permit the construction of interior masonry wythes and other backings prior to the construction of exterior facing wythes, permitting the structure to be enclosed faster. 2) Adjustable ties are two-piece systems. One piece is installed as the backing is constructed and the other piece is installed as the facing wythe is constructed, reducing the risk of damage to exposed ties that might occur when unit ties or standard joint reinforcement are used. 3) Adjustable ties can accommodate construction tolerances common in multi-material construction. 4) Adjustable ties can accommodate larger differential movements than standard unit ties or joint reinforcement.

The advantages offered by adjustable tie systems are not without possible problems: 1) Mislocation of adjustable ties placed prior to construction of facing wythes, if extreme, can render the ties useless. 2) Adjustable ties may encourage less than perfect layout of the wall system since a built-in adjustment allowance is available. 3) Large variations in construction tolerances may not allow full engagement of ties installed before facing wythes are constructed. 4) Improperly positioned ties may result in large vertical tie eccentricity. 5) The structural performance of some adjustable ties in regard to strength and stiffness is less than that of standard unit ties or joint reinforcement.

**Adjustable Unit Ties.** Adjustable unit ties produced for use with masonry backing, concrete backing, steel frames and steel studs are shown in Figs. 6 and 7. Slot-type ties (dovetail, channel slot, etc.) have been used for a number of years with concrete, steel frame and steel stud backing systems, and are recognized as tie systems capable of accommodating differential movement, as further discussed in *Technical Notes 18 Series* (see Fig. 6). Other types of adjustable unit tie systems are available for brick with masonry backing and other backing systems. These ties are typically two-piece systems, consisting of a single or double eye and pintle arrangement (see Fig. 7). The *Building Code Requirements for Masonry Structures* (ACI 530 / ASCE 5 / TMS 402-02) requires that for veneer masonry all pintle anchors have at least two pintle legs of wire size W2.8 (3/16 in., MW18) each and have an offset not exceeding 1 1/4 in. (31.8 mm). Typical installation details are shown in Fig. 8

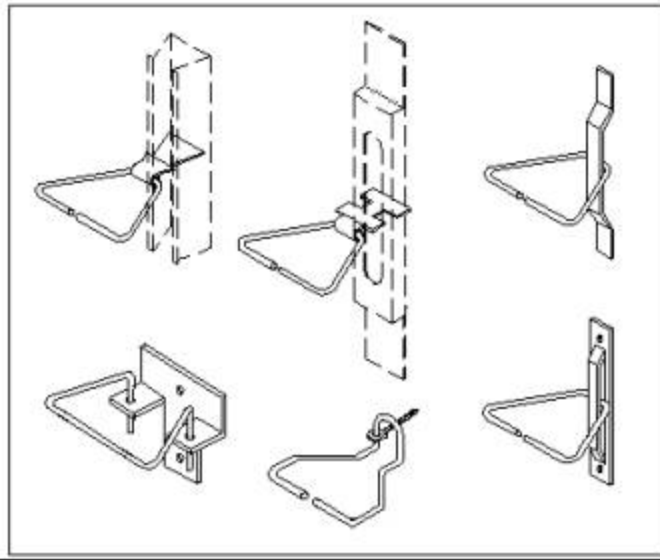

**Adjustable Unit Ties for Steel, Concrete and Stud Backup**  
**FIG. 6**

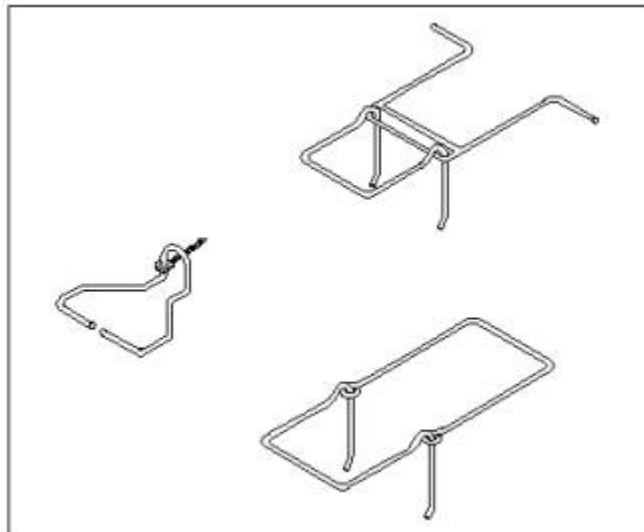

**Adjustable Unit Ties for Masonry Backup**  
**FIG. 7**

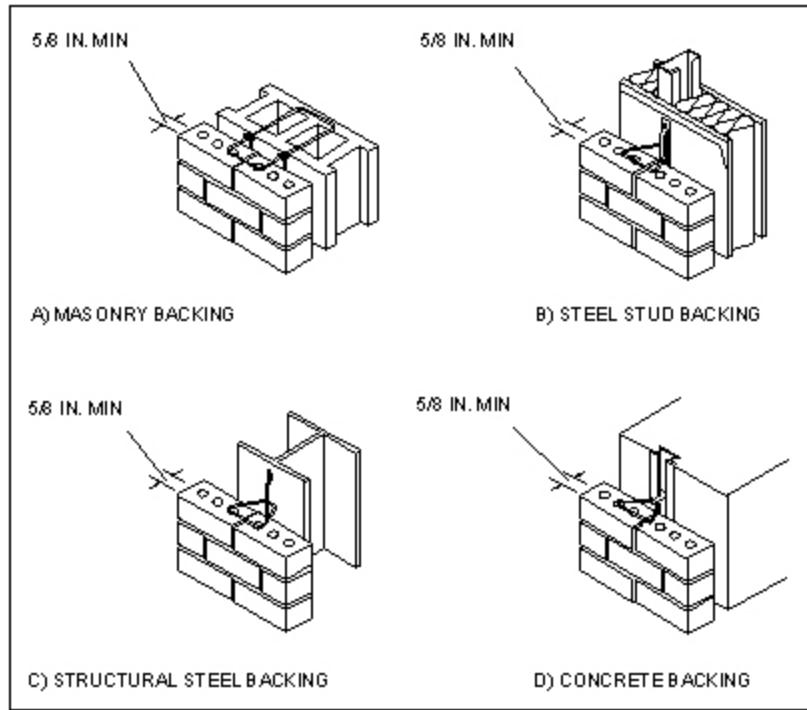

**Adjustable Unit Tie Details**  
**FIG. 8**

**Adjustable Assemblies.** Adjustable ladder and truss-type joint reinforcement assemblies are available for use in masonry backed-cavity wall, veneer and grouted wall construction. This joint reinforcement typically consists of rectangular tab type extensions, connected to standard joint reinforcement by means of an eye and pintle arrangement (see Fig. 9). Installation details are shown in Fig. 10.

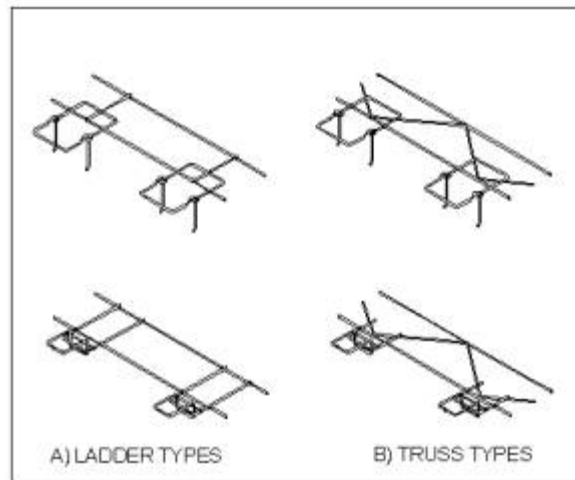

**Adjustable Joint Reinforcement Assemblies**  
**FIG. 9**

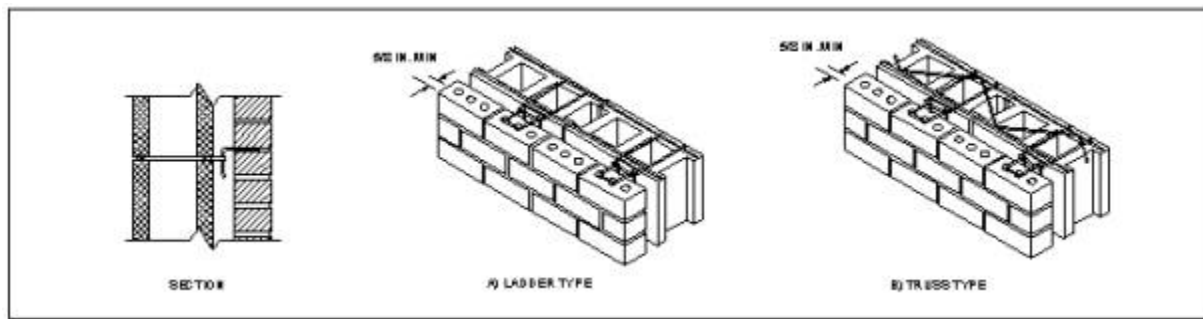

Adjustable Assembly Details

FIG. 10

### Masonry Re-anchoring Systems.

Masonry re-anchoring systems are the most recent development in masonry tie systems. Three general types of systems are being produced and typically consist of a mechanical expansion system, helical screw system and an epoxy adhesive system (see Fig. 11). These systems are primarily used to: provide ties in areas where ties were not installed during original construction, 2) replace existing ties, 3) replace failed masonry bonding units, 4) upgrade older wall systems to current code levels, or 5) attach new veneers over existing facades.

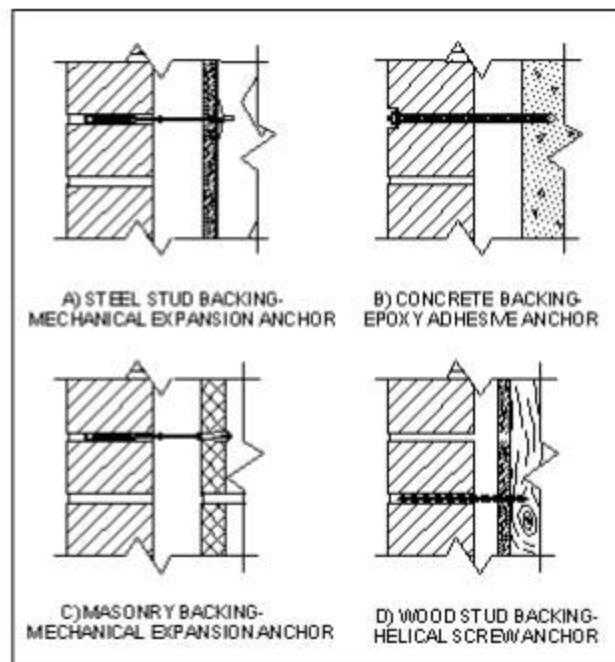

Masonry Re-Anchoring Systems

FIG. 11

As stated, re-anchoring systems are relatively new and many designers and contractors may not be fully familiar with their installation or limitations. For this reason, consultation with the tie system manufacturer is essential to assure proper application, detailing, installation, inspection, and performance.

### TIE SELECTION

#### Strength and Deformation

The strength and deformation characteristics of tie systems are not generally analyzed nor investigated during the project design or specification phase. Building codes and standards have typically required minimum tie size (diameter or gage) and maximum tie spacing limits to control tie loading and deformation. Present tie size and spacing requirements have been derived from some testing and from the past performance of traditional tie systems (rectangular ties, "Z" ties and standard joint reinforcement). The growing use of adjustable tie systems has caused some concerns in regard to tie strength and deformation. Most adjustable ties permit vertical adjustment up to approximately one-half the height of a standard brick unit,

some permit greater adjustments. Depending on the tie configuration, the deflections of adjustable ties can become quite large as vertical adjustment eccentricities are increased. This deflection is further increased if mechanical play is present in the tie system.

Analytical and experimental investigations of cavity wall and veneer wall systems have shown that tie loads and deformations are a function of: 1) the relative stiffness between facing and backing materials, 2) tie spacing, 3) tie stiffness, 4) support conditions of the facing and backing systems, 5) location of edges and openings, 6) cavity width and 7) applied loads.

Estimating tie loads based on tributary area can lead to large errors, depending on the geometry and properties of the wall system. Fig. 12 shows tie loads and deflections calculated from a simplified model of a cavity wall system. As shown, adjustable tie deflections become large as the adjustment eccentricity becomes large. These values were calculated assuming that no mechanical play existed in the tie system. Mechanical play must be added to these values to determine the total deflection of the exterior wythe. Typical adjustable ties have values of mechanical play ranging from approximately 0 to 0.3 in. (0 to 8 mm). Some adjustable ties may have an extreme amount of mechanical play when not properly installed (see Fig. 13). The MSJC Code limits mechanical play to a maximum of 1/16 inch (1.6 mm). If satisfactory performance is to be expected, total tie and backing deflections must be maintained within the working range of the masonry facade under full design loads.

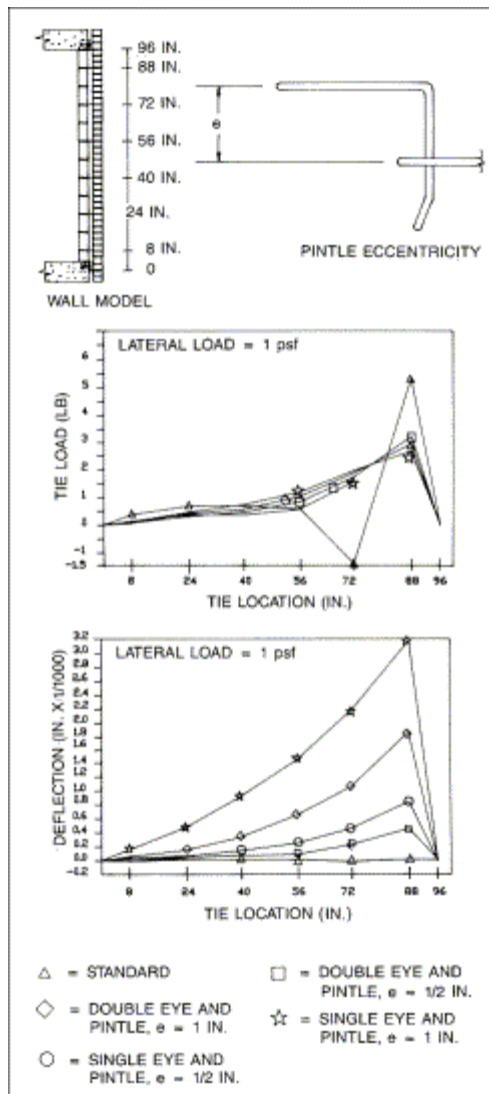

Calculated Tie Loads and Deflections  
FIG. 12



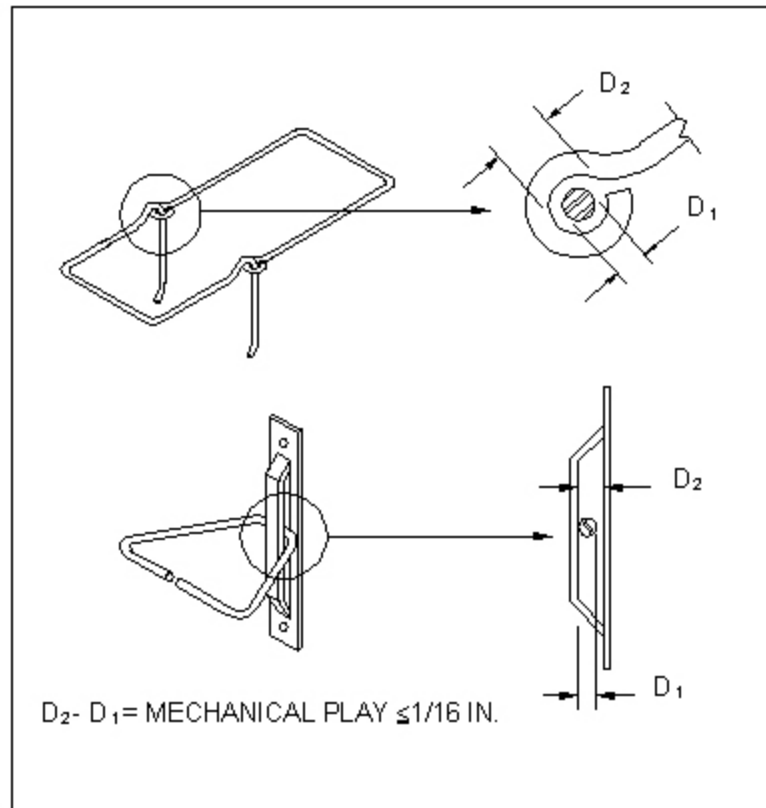

**Mechanical Play**  
**FIG. 13**

**Recommendations.** At present, analysis techniques that accurately model metal-tied wall systems are still in the developmental stage and require further refinement and verification through testing. Until more accurate methods are available, the Brick Industry Association feels that acceptable strength and deformation characteristics can be achieved by one or more of the following measures: 1) Reduce or eliminate lateral mechanical play in adjustable tie systems. Limit the total mechanical play to 1/16 in. (1.6 mm), see Fig. 13. 2) Reduce or eliminate adjustment eccentricity in adjustable tie systems. This can be accomplished by installing ties as facing wythes are constructed or by using starter courses or ledges when facing wythes are constructed over masonry backing. 3) Eliminate possible disengagement of adjustable ties by providing positive vertical movement limitations. 4) Provide additional ties within 8 in. (200 mm) of openings and discontinuities, i.e., windows, shelf angles, vertical expansion joints, etc. 5) Do not specify ties with formed drips. Testing has shown that drips can reduce the ultimate buckling load by approximately 50 percent. 6) Space ties as shown in Table 1, based on the tie system and wall system. 7) Specify stiff ties. This can be accomplished by specifying ties with maximum deflections of less than 0.05 in. (1.2 mm) when tested at an axial load of 100 lb in tension or compression. When adjustable ties are specified, the deflection limit should be satisfied at the eccentricity expected in the field. See Table 2 for minimum tie gage and diameter recommendations. 8) Select an appropriate tie system for the wall system (see Table 3). Many of these recommendations have been incorporated in the MSJC Code.

**TABLE 1**  
**Tie Spacing Requirements<sup>1,2</sup>**

Wall Type	Tie System and Material	Maximum Cavity Width <sup>2</sup> , in. (mm)	Maximum Area Per Tie, ft <sup>2</sup> (m <sup>2</sup> )	Maximum Vertical Spacing, in. (mm)	Maximum Horizontal Spacing, in. (mm)
Cavity (Both Wythes Designed to Resist Out of Plane Stresses)	Unit Tie W1.7 W2.8	4 ½ (114)	2.67 (0.25) 4.50 (0.42)	24 (610)	36 (914)
	Standard Joint Reinforcement W1.7 W2.8	4 ½ (114)	2.67 (0.25) 4.50 (0.42)	24 (610)	16 (406)
	Unit Adj. Double Eye & Pintle	4 ½ (114)	1.77 (0.16)	16 (406)	16 (406)
	Adj. Joint Reinforcement	4 ½ (114)	1.77 (0.16)	16 (406)	16 (406)
Brick Veneer/ Wood Stud	Corrugated	1 (25)	2.67 (0.25)	18 (457)	32 (813)
	Other than Corrugated	4 ½ (114)	2.67 (0.25)	18 (457)	32 (813)
	Adj. 2 piece W1.7		3.50 (0.33)		
Brick Veneer/ Steel Stud	Adj. Unit Veneer Ties	4 ½ (114) (2 in. (50 mm) recommended)	2.67 (0.25) (2.0 ft <sup>2</sup> (0.18 m <sup>2</sup> ) recommended)	18 (457)	32 (813) (24 in. recommended)
Brick Veneer/ Concrete or CMU Backing	Adj. Unit and W1.7	4 ½ (114)	2.67 (0.25)	18 (457)	32 (813)
	Sheet Metal and W2.8		3.50 (0.33)		
Multi Wythe Masonry Composite	Unit ties W1.7 W2.8	No Cavity	2.67 (0.25) 4.50 (0.42)	24 (610)	36 (914)
	Joint reinforcement W1.7 W2.8		2.67 (0.25) 4.50 (0.42)	24 (610)	36 (914)

1. Masonry laid in running bond. Consult applicable building code for special bond patterns such as stack bond.
2. Based on the requirements in the 2002 MSJC Code.
3. Maximum allowable distance between inside face of veneer and framing material, per MSJC Code, unless noted otherwise.

**TABLE 2**  
**Required Tie Sizes<sup>1</sup>**

Tie System		Minimum Specified Dimension <sup>1</sup>		
		Wire Size	Gage	Dimension, in. (mm)
Unit Ties	Rectangular and "Z"	W1.7 W2.8	9 ---	0.15 (3.8) 3/16 (4.8)
	Corrugated	Not applicable	22	0.03 (0.8)
Joint Reinforcement, Standard and Adjustable	Ladder and Truss Type and Tabs	W1.7 W2.8	9 ---	0.15 (3.8) 3/16 (4.8)
Adjustable ties	Rectangular and "Z"	W1.7 W2.8 (pintle legs min. W2.8)	9 ---	0.15 (3.8) 3/16 (4.8)
	Dovetail/ Channel Slot Wire	W1.7 W2.8 (pintle legs min. W2.8)	9 ---	0.15 (3.8) 3/16 (4.8)
	Sheet Metal Connector Slot	Not applicable Not applicable	16 22	0.06 (1.5) 0.03 (0.8)
	Slotted Plate Wire	W1.7	9	0.15 (3.8)
	Slotted Plate Backer Plate	Not applicable Not applicable	14 14	0.08 (2.0) 0.08 (2.0)

<sup>1</sup> Based on the requirements in the 2002 MSJC Code.

Wall System	Tie System <sup>1</sup>							Comments
	Rectangular Tie, Fig. 2	"Z" Tie, Fig. 2	Corrugated Tie, Fig. 2	Std. Jt. Reinforcement, Fig. 4	Adj. Unit Ties Mas. Backup, Fig. 7	Adj. Unit Veneer Ties, Fig. 6	Adj. Jt. Reinforcement, Fig. 9	
Brick Veneer/Wood Stud			X					1. 38 ft. (11.6 m) or less in height.
Brick Veneer/Steel Stud						X		1. mechanical play limited to 0.02-0.05 in. max. 2. Limit tie deflection to 0.05 in. max. at 100 lb.
Brick Veneer/Steel or Concrete						X		1. Concrete backup - dovetail, channel slot, ties with concrete fasteners. 2. Steel - channel slot, weld-on ties with steel fasteners. 3. Mechanical play and deflection limits: see brick/veneersteel stud.
Cavity or Brick Veneer/CMU	X	X		X	X		X	1. "Z" ties with solid units only. 2. Adjustable unit ties and adjustable joint reinforcement. Limit mechanical play to 0.02-0.05 in. max. Limit tie deflection to 0.05 in. max. at 100 lb. 3. No truss-type joint reinforcement.
Multiple-Wythe Brick	X	X		X			X	1. "Z" ties with solid units only. 2. Full collar joints.
Brick/Block Composite	X			X	X		X	1. Full collar joint.

<sup>1</sup> See Table 1 for spacing; Table 2 for sizes and gages; Table 5 for corrosion protection.

## Corrosion

**General.** Awareness of possible corrosion problems in metal-tied masonry walls has increased due to corrosion damage found on reinforcement in concrete highway pavements, bridge decks and some masonry structures. The potential for corrosion problems in masonry has increased as construction and design philosophies have changed and as environmental conditions have changed over the last decades. These changes include use of thinner masonry walls and masonry veneers that are more susceptible to water penetration, increases in atmospheric pollutants, use of accelerators containing calcium chloride, increased use of insulated cavities (resulting in the relocation of the dew point within the wall section) and combinations of different metals in brick veneer wall systems. This list is not all-inclusive; corrosion potential can also be affected by the function of a structure, geographic location, compatibility of construction materials, detailing and workmanship.

**Corrosion Protection.** In order to provide corrosion protection, environmental factors must be controlled or metals used in construction must be protected. Conventional corrosion protection methods attempt to protect metals embedded in masonry by isolating them with impervious coatings (barrier protection), by using metals that are corrosion-resistant, or by providing cathodic protection in which one metal becomes sacrificial to protect another.

**Galvanizing** — Galvanizing (zinc-coating) provides resistance to corrosion by two methods. First, the zinc coating acts as a barrier shielding the underlying steel from corrosive action. Second, it acts as a sacrificial element that is consumed before the base steel is attacked. This sacrificial nature protects the base steel at scratches and discontinuities in the zinc coating caused by fabrication, handling or installation, until most of the adjacent zinc coating is consumed. Studies have shown that the protective value of zinc coating is proportional to its thickness. Thus, for longer periods of protection, a thicker zinc coating is required. Also, when the protective zinc coating is depleted, the corrosion of the base steel will progress as if no galvanizing were present.

Two methods of galvanizing are used to protect metal masonry ties: mill galvanizing and hot-dip galvanizing. Mill galvanizing takes place after steel wire or sheets have been processed to their specified dimensions and prior to fabrication of the tie. During the mill galvanizing process, zinc can be applied in a variety of thicknesses, as shown in Table 4. Hot-dip galvanizing is performed by dipping completely fabricated assemblies into molten zinc until a specified amount of zinc is bonded to the base metal. Hot-dip galvanized coatings are typically thicker than mill galvanized coatings and therefore, provide longer periods of protection.

**TABLE 4**  
**Coating Requirements**

Coating Process	ASTM Specification	Piece to be Galvanized	Minimum Coating, oz.ft <sup>2</sup> (mils)
Mill Galvanizing	A 641	Wire: W 1.7 (9 gage) and W2.8 (3/16 inch diameter)	Class 1: 0.4 (0.72)
			Class 2: 0.6 (1.08)
			Class 3: 0.8 (1.44)
Hot-dip Galvanizing	A 653	Steel Sheet	G60: 0.6 (1.08)
	A 153	Class B <sup>1</sup>	
		Class B-1	2.0 (3.6)
		Class B-2	1.5 (2.7)
	Class B-3	1.3 (2.3)	

<sup>1</sup>Class B — Rolled, pressed or forged articles.

B-1: 3/16 in. (4.8 mm) and over in thickness and over 15 in. (381 mm) in length

B-2: Under 3/16 in. (4.8 mm) in thickness and over 15 in. (381 mm) in length.

B-3: Any thickness and 15 in. (381 mm) and under in length.

**Stainless Steel** - Stainless steel ties are often specified for use in very corrosive environments. Stainless steel ties are specified under ASTM A 240 or A 580 and are generally made from one of the austenitic stainless steels. Stainless steel resists corrosion well; however, if in contact with carbon steel, a galvanic cell can result and actually increase the potential for corrosion. For this reason, combining stainless steel ties or screws with carbon steel or galvanized steel components is not recommended.

**Fusion-Bonded Epoxy** — Epoxy coating is the newest process used to provide corrosion protection for metal ties. The process has been adapted from epoxy-coated reinforcement bars used successfully in concrete systems with severe environmental exposures. Epoxy coating provides protection by acting as an impervious barrier. The epoxy coating is bonded to the base steel by a heat-induced chemical reaction through which a chemical and mechanical bond is formed. The combination of the two types of adhesion helps to prevent cracking of the coating due to handling, installation or stress reversals. The epoxy coating is not sacrificial like zinc; therefore, nicks and voids in the coating can lead to corrosion of the base steel. Epoxy coatings for joint reinforcement should meet the requirements of ASTM A 884, Class A, Type 1 - 7 mils. Epoxy coatings for wire ties and anchors are specified in ASTM A 899, Class C - 20 mils. Sheet metal ties and anchors should be coated with 20 mils of epoxy per surface or per manufacturer's specification.

**Recommendations.** The past performance of metal ties in regard to corrosion has generally been satisfactory. The American Galvanizers Association has developed a Zinc Coating Life Predictor program that provides an estimate of service life for zinc coating in an exposed environment. This does not specifically address performance of ties in masonry walls. Until research can produce accurate methods of assessing corrosion potential and predicting adequate levels of protection, the Brick Industry Association suggests minimum levels of corrosion protection for metal ties and hardware as indicated in Table 5. As with all other engineering considerations minimum recommendations may not be adequate in every situation, and should not serve as substitutes for engineering investigation or judgment. Decisions must be based on individual project conditions, performance requirements and safety.

**TABLE 5**  
**Recommended Minimum Corrosion Protection**

Application	Corrosion Protection
<u>Unit Wire Ties</u>	
1. Completely embedded in mortar or grout	1. ASTM A 641, Class 3
2. Exposed in air spaces or cavities	2. ASTM A 153, Class B-3 or ASTM A 899, Class C, 20 mils
3. Exposed to corrosive elements	3. ASTM A 580, Type 304
<u>Sheet Steel Ties</u>	
1. Completely embedded in mortar or grout	1. ASTM A 653, Class G 60
2. Exposed in air spaces or cavities	2. ASTM A 153, Class B-3 or 20 mils epoxy per surface
3. Exposed to corrosive elements	3. ASTM A 240, Type 304
<u>Joint Reinforcement</u>	
1. Completely embedded in mortar or grout	1. ASTM A 641, Class 3
2. Exposed in air spaces or cavities	2. ASTM A 153, Class B-2 or ASTM A 884, Class A, Type 1 – 7 mils
3. Exposed to corrosive elements	3. ASTM A 580, Type 304

### SUMMARY

This *Technical Notes* is the third in a series addressing brick masonry anchor bolts, fasteners and wall ties. It is primarily concerned with the types of wall ties commonly used in brick masonry construction, their function, selection, specification and installation. Other *Technical Notes* in this series individually address anchor bolts and fasteners for brick masonry.

The information and suggestions contained in this *Technical Notes* are based on the available data and the experience of the engineering staff of the Brick Industry Association. The information contained herein must be used in conjunction with good technical judgment and a basic understanding of the properties of brick masonry. Final decisions on the use of the information contained in this *Technical Notes* are not within the purview of the Brick Industry Association and must rest with the project architect, engineer and owner.

### REFERENCES

1. DeVekey, R.C., "Corrosion of Steel Wall Ties: Recognition, Assessment and Appropriate Action", Building Research Establishment Information Paper, IP 28/79, Building Research Establishment, Garston, Watford, England, October 1979.
2. Fishburn, C.C., "Water Permeability of Walls Built of Masonry Units", Report BMS 82, National Bureau of Standards, Department of Commerce, Washington, D.C., April 1942.
3. Allen, M. H., Research Report No. 10, "Compressive and Transverse Strength Tests of Eight-Inch Brick Walls", Structural Clay Products Research Foundation, Geneva, Illinois, October 1966.
4. Allen, M.H., Research Report No. 14, "Compressive Strength of Eight-Inch Brick Walls with Different Percentages of Steel Ties and Masonry Headers", Structural Clay Products Research Foundation, Geneva, Illinois, May 1969.
5. Bortz, S.A., "Investigation of Continuous Metal Ties as a Replacement for Brick Ties in Masonry Walls", Summary Report ARF 6620, Armour Research Foundation, Chicago, Illinois, June 1960.
6. "Investigation of Masonry Wall Ties", ARF Project B870-2 (Revised), Armour Research Foundation, Chicago, Illinois, December 1962.
7. "Flexural Strength of Cavity Walls", ARF Project B870, Armour Research Foundation, Chicago, Illinois, March 1963.
8. Brown, R.H. and Elling, R.E., "Lateral Load Distribution in Cavity Walls", Proceedings of the Fifth International Brick Masonry Conference, Washington, D.C., October 1979.
9. Bell, G.R. and Gumpertz, W.H., "Engineering Evaluation of Brick Veneer/Steel Stud Walls, Part 2 —Structural Design, Structural Behavior and Durability", Proceedings of the Third North American Masonry Conference, Arlington, Texas, June 1985.
10. Arumala, J.O. and Brown, R.H., "Performance of Brick Veneer With Steel Stud Backup", Clemson University, Clemson, South Carolina, April 1982.

11. "Development of Adjustable Wall Ties", ARF Project No. B869, Armour Research Foundation, Chicago, Illinois, March 1963.
12. Catani, Mario J., "Protection of Embedded Steel in Masonry", *The Construction Specifier*, January 1985.
13. Catani, Mario J. and Whitlock, A. Rhett, "Coping With Wide Cavities", *The Construction Specifier*, August 1986.
14. Zhang, X. Gregory, *Zinc Coating Life Predictor*, The International Lead Zinc Research Organization, published online at <http://zclp.galvanizeit.org:8180/zclp/index.html>, 2002.