



TECHNICAL NOTES on Brick Construction

1850 Centennial Park Drive, Suite 301, Reston VA 20191 | www.gobrick.com | 703-620-0010

Technical Notes 26 - Single Wythe Bearing Walls Sept. 1994

Abstract: Brick masonry bearing wall systems have been used for years for their strength, durability and other inherent values. Once widely used in single family residential construction, this application is experiencing a resurgence in interest. New designs possible with a single wythe of brick are discussed in this *Technical Notes*. Selection of materials and recommended details for one and two story designs are addressed.

Key Words: bearing wall, brick, reinforced brick masonry, single wythe wall.

INTRODUCTION

The rising cost of wood framing members has created a renewed interest in alternative building systems for residential housing. The use of light-gage steel framing is one alternative. Another is the use of single wythe brick bearing walls. The use of brick masonry as the load-carrying element of a structure provides several benefits over other alternate systems. Using brick as both the building's exterior skin and its structure capitalizes on brick masonry's strength and other inherent values. Brick gives a home permanence and beauty. Brick homes have lower maintenance costs and often lower insurance rates because of their fire resistant characteristics. Because of their thermal mass properties, brick homes are more energy efficient than comparably insulated vinyl- or wood-sided homes. For these reasons, brick homes have a higher resale value.

In a single wythe brick bearing wall system, the brick masonry serves as both the structural system and the exterior facing. A wood, steel or masonry backing system is not necessary. The interior living space of a brick bearing wall home may be the same as that of a framed home. Floor and roof elements and interior partitions are constructed with the same materials as used in frame homes. Home plans may include one or two story structures, expansive master bedrooms and other popular amenities. In brick bearing wall homes, attractive features such as brick masonry fireplaces and special brick details can be readily incorporated to set the house apart.

The design and construction of single wythe brick bearing wall systems are discussed in this *Technical Notes*. Typical details for residential applications are provided. Although this *Technical Notes* illustrates residential construction, single wythe brick bearing walls are equally appropriate in commercial construction, and many of the design and material considerations discussed in this *Technical Notes* are the same.

DESIGN CONSIDERATIONS

Single wythe brick loadbearing walls include the same design considerations as other types of wall systems. Model building codes dictate the minimum loads to be resisted by the structural system, the minimum thermal performance requirements and the necessary fire resistance of the wall system. Since a brick bearing wall system forms the building envelope, the designer must also consider resistance to moisture penetration and detailing of interior finishes. These concerns are addressed in the sections that follow.

Structural Considerations

The design of any structural system begins with the determination of the design loads. Design loads include vertical loads from the weight of the building materials and occupants and lateral (horizontal) loads from wind, soil and seismic forces. In most residential structures, the controlling forces are the expected vertical loads plus wind loads. In certain regions of the United States, predominantly the west coast, seismic loads may control the structural design.

The model building codes and the associated structural loads will dictate the size of the building's structural members. Model building codes have two methods of design: empirical and rational. In the case of loadbearing masonry, all model building codes specify the minimum wall thicknesses and maximum wall height or number of stories for empirical designs. Generally, these limitations are not applicable to buildings which have been rationally designed. However, the distinction in model building code limitations for engineered (rational) versus empirically designed masonry structures is not always clear. Furthermore, even a rational design will include some prescriptive detailing requirements. The masonry standard used for the structural design of brick bearing walls in this *Technical Notes* is the *Building Code Requirements for Masonry Structures* (ACI 530/ASCE 5/TMS 402) and its companion *Specifications for Masonry Structures* (ACI 530.1/ASCE 6/TMS 602) [4], referred to as the MSJC Code and Specifications, respectively. Other masonry design criteria, such as Chapter 21 of the Uniform Building Code, could also be used.

The most widely used residential building code is the CABO *One- and Two-Family Dwelling Code* [5]. The CABO Code is an empirical code which specifies an 8 in. (200 mm) minimum nominal wall thickness for loadbearing masonry structures over one story in height. For single-story homes, a nominal 6 in. (150 mm) wall is permitted, so long as the wall height does not exceed 9 ft (2.7 m) and the gable height does not exceed 15 ft (4.6 m). In cases where these limits are applied, the minimum wall thickness requirements will influence the type and size of brick unit used. When rationally designed, these limits on wall size can be exceeded. Other model building codes have similar prescriptive restrictions, but permit rational design, not subject to these limits, when using approved masonry standards.

Loadbearing brick masonry houses may be built with walls less than 6 in. (150 mm) in nominal thickness when rationally designed. These walls may require vertical steel reinforcing bars and horizontal reinforcing bars or wires. Typically, vertical steel reinforcing bars are used to resist lateral loads and horizontally reinforced bond beams are used to attach floor and roof members. Additional horizontal reinforcement is required over large openings and in areas of high seismicity. This *Technical Notes* provides details for location of vertical reinforcement and horizontal bond beams when used in brick bearing wall construction.

The designer of a brick bearing wall must specify the properties of the materials necessary to meet the structural requirements of the design. The compressive strength of the brick masonry assembly, f_m , must be specified. Mortar and grout type or properties should be identified. Type, size and grade of reinforcement, if used, should also be specified. See *Technical Notes* 3 Series for further information on the structural design of brick bearing walls using the MSJC Code.

Energy Considerations

The model building codes contain requirements to ensure acceptable thermal performance of the building envelope. Minimum levels of insulation are required, and in some cases, air leakage is addressed. Type and installation of insulation in a single wythe brick bearing wall system differ from those in other residential wall systems. In wood frame residential structures, batt insulation is typically placed between the wood studs. For brick bearing wall homes, rigid board insulation is often placed on the interior face of the brick wythe. Rigid board insulation has the advantages of being easy to install and providing high insulation values. Installation of the insulation board on the interior of the brick wythe is coordinated with the interior finish materials and with the flashing and drainage system used to control water penetration. Options for attaching rigid insulation include square, "Z" or other shaped furring strips, mechanical fasteners and adhesives. Alternately, insulation may be placed in the cells of hollow brick units. However, this application is limited to large hollow units most commonly used in commercial brick bearing wall buildings. Furthermore, such insulation is generally not as effective as a continuous layer of insulation placed on the inside face of the single wythe wall, due to the discontinuity of the insulation at the webs of the units.

Air leakage through the building envelope may also be a concern. Although the brick wall provides an effective air barrier, there will be some leakage through weep holes and at the top of the brickwork. Building paper or sheet membrane materials, called "house wraps", are commonly installed over exterior sheathing materials in wood frame construction to prevent air leakage. However, these materials are not appropriate for direct application on brick bearing walls. Alternate approaches to further limit air leakage are the use of either foil-faced rigid board insulation or so-called "air-tight drywall". These approaches rely on the air penetration resistance of the paper or other films on the insulation or gypsum board. To achieve an impenetrable air barrier, the joints between the sheets of insulation or gypsum board should be sealed or taped. Joints between

dissimilar materials, and joints around door and window frames, should also be sealed.

Water Penetration Resistance

Water penetration is one of the chief concerns in the performance of any exterior wall system. Resistance to water penetration of the brick masonry wythe is of utmost importance in single wythe construction. Full mortar joints and good extent of bond between units and mortar help to reduce water penetration. The head joints in hollow brick masonry should be laid full, not face-shell mortar bedded only. *Technical Notes 7 Series* provides further information on water penetration resistance of brick masonry wall systems.

A single brick masonry wythe may not prevent water penetration entirely. Therefore, a drainage cavity with flashing and weep holes should be provided. If a drainage cavity is not used, a bituminous, damp-proof coating should be applied to the inside face of the brick bearing wall prior to installation of the insulation and finishes. Material compatibility of the coating with adjacent materials should be considered. In regions of the country which are subject to large amounts of rainfall or severe wind-driven rain, the use of a clear water repellent coating on a wall built with good workmanship and proper details may be appropriate with this wall type.

Location of Interior Work and Finishes

The installation of plumbing, heating and electrical systems in a loadbearing brick home will vary slightly from their placement in conventional frame construction. There is no cavity between studs for the placement of piping or conduit, and piping or conduit should not be placed within the brick wythe. Instead, the plumbing, heating and electrical piping or conduit can be installed between furring strips on the brick bearing wall, in the floor or ceiling or in interior frame walls. The type of foundation will influence the location of interior systems. In slab-on-grade construction, it is easiest to route the mechanical systems through the ceiling space. With basement or crawl space foundations, it is possible to locate mechanical systems between the first floor joists.

The interior finish materials used in brick bearing wall homes are the same materials as those used in frame construction. However, the installation of interior finishes varies. In brick veneer construction, interior gypsum board is typically nailed or screwed to the studs. In brick bearing wall construction, gypsum board or other interior finishes may be nailed or screwed to furring strips or light-gage metal studs, anchored to the masonry with special clips or ties, nailed to special nailing inserts in the masonry or adhesively attached over the brick masonry wythe and insulation. Some common methods are discussed in *Construction Details*.

Cabinets and other built-in items can be attached directly to the brick masonry walls or to furring strips attached to the masonry. Wood 2 by 4's, spaced to support the cabinets or other built-in items, can be attached to the brick masonry using anchor bolts placed in the masonry wall or by expansion anchors, adhesive anchors or other brick anchors and fasteners installed in the completed masonry. *Technical Notes 44 and 44A* provide a complete description of suitable brick anchors and fasteners. Insulation may be placed between the 2 by 4's, and cabinets then placed over insulation and attached to the furring using conventional techniques. Cabinets may also be supported by stud framing built inside the brick bearing wall, in a manner similar to brick veneer construction.

MASONRY MATERIAL SELECTION

Selection of masonry materials for a brick bearing wall system should consider structural, energy and other performance requirements as discussed in this *Technical Notes*. Further information on material selection for adequate strength and compliance with the MSJC Code and Specifications can be found in *Technical Notes 3 Series*.

Brick

Brick used in single wythe bearing wall structures may be either solid or hollow. Solid units should meet the requirements of ASTM C 216 Specification for Facing Brick. Hollow units should meet the requirements of ASTM C 652 Specification for Hollow Brick. Structural and model building code requirements, aesthetics, availability and cost will determine the minimum unit compressive strength, type and sizes of units used. Brick unit compressive strengths range from 1,700 psi to

36,000 psi (12 to 250 MPa), with a mean value of over 5,200 psi (36 MPa) for molded brick and over 11,300 psi (77 MPa) for extruded brick [1]. Brick unit strength is directly related to compressive strength of the brick masonry assembly. *Technical Notes 3A* should be reviewed for material properties of brick masonry.

There are numerous brick sizes manufactured today. Solid units are commonly manufactured in nominal widths of 3, 4 and 6 in. (75, 100 and 150 mm). Hollow units, which are less than 75 percent solid, are manufactured in nominal widths of 4 in. (100 mm), 5 in. (125 mm), 6 in. (150 mm) and 8 in. (200 mm). See *Technical Notes 10B Revised* for a more complete listing of sizes currently manufactured. Nominal 5 and 6 in. (125 and 150 mm) wide hollow brick are the most common units used to build reinforced brick bearing wall homes.

Hollow brick are prevalent in reinforced brick bearing walls because they have cells which can accommodate vertical reinforcement and grout. The minimum size of cells in hollow units intended to be reinforced is dictated by the MSJC Code and listed in Table 1. Larger bars, horizontal reinforcing bars and coarse grout require larger cell sizes. When reinforcement is required, solid brick may be cut to form grout pockets or incorporate pilasters to accommodate vertical reinforcement. For further information on grouting requirements see the MSJC Code and Specifications and *Technical Notes 3B*.

Uniform spacing of vertical reinforcement is important in the design and construction of reinforced loadbearing masonry walls. Cell size and unit length should be coordinated to provide cells which align vertically for ease of grouting and uniform spacing of reinforcing bars. Most hollow brick designed to accommodate reinforcing bars have lengths equal to twice their width, so that cells align vertically when the masonry is laid in half running bond. Spacing of reinforcement should be selected with these dimensions in mind.

TABLE 1
Minimum Cell Size ¹

Grout Type	Max. Grout Pour Ht., ft (m)	Min. Clear Cell in. x in. (mm x mm)	Max. Vertical Bar Size ² (Metric Bars)
Fine	1.0 (0.3)	1 1/2 x 2 (40 x 50)	No. 3 (10)
	5 (1.5)	2 x 3 (50 x 75)	No. 5 (15)
	12 (3.7)	2 1/2 x 3 (70 x 75)	No. 6 (20)
Coarse	1 (0.3)	1 1/2 x 3 (40 x 75)	No. 4 (10)
	5 (1.5)	2 1/2 x 3 (70 x 75)	No. 6 20
	12 (3.7)	3 x 3 (75 x 75)	No. 6 (20)

¹Metric dimensions are based on metric reinforcing bar sizes as specified in ASTM A 615M.

² Area of reinforcing bar should not exceed 6 percent of cell void area.

Mortar

The strength and water penetration resistance of a brick bearing wall is dependent upon the mortar selected. Portland cement-lime mortars with an air content less than 12 percent are recommended for their superior bond strength and resistance to water penetration. In unreinforced loadbearing masonry, the MSJC Code allowable flexural tensile stresses are reduced approximately 50 percent for assemblies made with masonry cement mortars or portland cement-lime mortars with air content over 12 percent. In addition, some codes prohibit the use of masonry cement mortars and all Type N mortars in Seismic Performance Categories D and E (formerly Seismic Zones 3 and 4). Mortar should meet the proportion requirements of ASTM C 270 Specification for Mortar for Unit Masonry. Type S, M or N mortar may be used in loadbearing brick masonry, although Type S is

recommended for use in reinforced brick bearing walls.

Grout

Grout is used in reinforced brick masonry to bond steel reinforcement to the surrounding brick masonry. Grout for masonry may be made from either fine or coarse aggregate, although fine grout is typically used for ease of grouting smaller cells. Aggregate type influences the size of grout space needed. (See Table 1.) Grout should meet the proportion requirements of ASTM C 476 Specification for Grout for Unit Masonry, and use of a shrinkage compensating admixture is recommended. The water/cement ratio of grout is not typically specified, but the water content should be sufficient to provide a mixture which has a slump of 8 to 11 in. (200 to 275 mm). Grout should be fluid enough to fill voids, but not separate into its constituents.

Reinforcement

Vertical steel reinforcement is often used in brick bearing walls to provide resistance to lateral loads. Size and spacing of reinforcement required are a function of design loads, unit size, compressive strength of the masonry assemblage and cell spacing. The MSJC Code limits the maximum size of reinforcement used in masonry to a No. 11 reinforcing bar. As a rule-of-thumb, the maximum bar size should not exceed the nominal thickness of the wall in inches to ensure proper development of the reinforcement. For example, a maximum reinforcing bar size of No. 6 is recommended for nominal 6 in. (150mm) walls.

Steel reinforcing bars should conform to ASTM Specification A 615, A 615M, A 616, A 617 or A 706, depending upon the type of bar used. Joint reinforcement, if used, should comply with ASTM A 82 and be hot-dipped galvanized or made from stainless steel to reduce the possibility of corrosion.

Construction Details

There are several features of a brick bearing wall system which differ from brick veneer wall systems. The construction of loadbearing brick masonry may incorporate reinforcement and must provide support and attachment of floors and the roof. Openings for windows and doors may be spanned by self-supporting reinforced or unreinforced brick masonry. Water penetration resistance and thermal resistance are generally provided by methods other than the traditional drainage cavity and insulation between wood studs. Possible details for construction of these features in a brick bearing wall system follow. The structural details and methods of attaching the insulation and interior finishes shown vary from figure to figure to illustrate the variety of options available. No single method is preferred in all cases, nor are all possible options shown.

Bearing Wall Reinforcement

A loadbearing brick wall often contains vertical steel reinforcement uniformly spaced along the length of the wall and horizontal reinforcement in bond beams. Vertical reinforcement may also be necessary around openings and at building corners. Figure 1 illustrates one means of incorporating vertical reinforcing bars in a wall built of solid units. In this case, horizontal joint reinforcement may be required in bed joints and formwork is necessary to contain the grout in the grout pocket until it has cured. The brick units will require special cutting to form the grout pocket within the wall thickness.

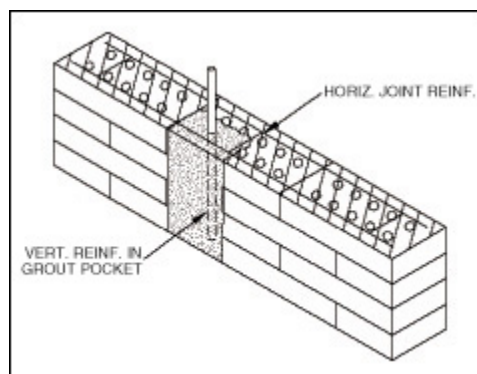

Solid Brick With Grout Pocket

Fig. 1

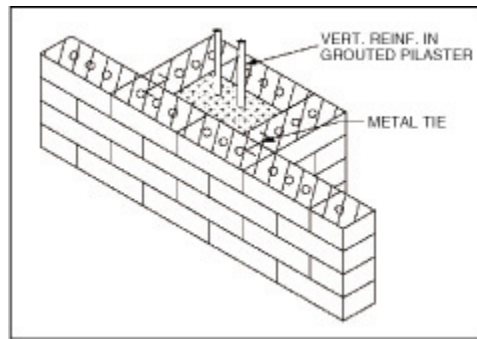

Pilaster Built with Solid Brick
Fig. 2

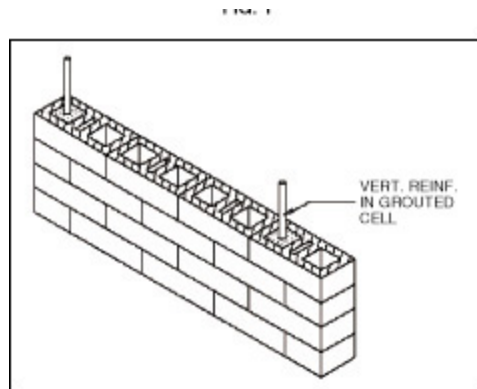

Reinforced Hollow Brick
Fig. 3

Alternately, brick bearing walls built with solid units may incorporate pilasters, as shown in Fig. 2, to provide the necessary confinement of vertical reinforcement. The advantage of using pilasters is that no forms are required. They may, however, occupy a significant amount of floor space if located on the interior side of the wall.

Masonry walls constructed with hollow units may be vertically reinforced as shown in Fig. 3. By providing the necessary reinforcement within the cells of the unit, hollow brick bearing walls can optimize the wall section. The design and detailing of reinforcement should follow the provisions of the MSJC Code and Specifications. In some cases, such as at terminations or splices of vertical reinforcing bars, special attention may be necessary to accommodate multiple or hooked reinforcing bars within the confines of the cells of hollow brick. Technical Notes 3B provides examples of common reinforced pilasters and reinforced hollow brick walls.

Horizontally reinforced bond beams are used to anchor bolts for attaching ledgers and plates and to span wall openings. Bond beams are formed by removing part of the cross webs of hollow brick or by using special U-shaped units. Necessary anchor bolts and reinforcement are placed, and the bond beam is grouted solid. The depth of the bond beam required will depend on the design loads for the structure, the material properties of the masonry and the amount of reinforcement used.

Connections

Foundation. Brick bearing walls may be supported on poured concrete, concrete masonry or brick masonry foundation walls. If construction incorporates a slab on grade, the foundation wall may be built as shown in Fig. 4.

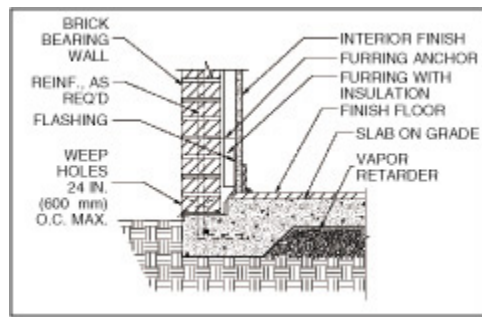

Slab-On-Grade Foundation
Fig. 4

When a crawl space or basement is present, the floor joist system may be supported directly on the foundation wall (Fig. 5),

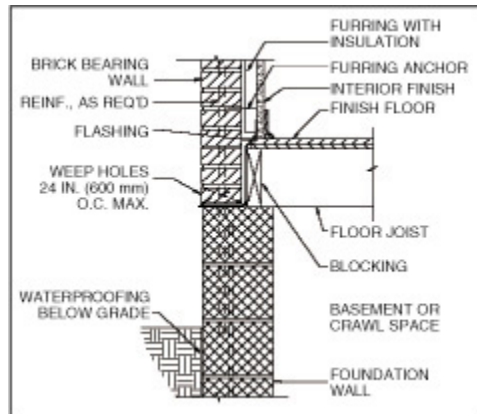

Basement or Crawl Space Foundation
Fig. 5

on corbeled brickwork (Fig. 6) or on a ledger joist bolted onto a bond beam (Fig. 7). The details of support will vary depending upon the size of foundation wall and the width of the brick bearing wall above the foundation. A minimum bearing of 3 in. (75 mm) should be provided for floor joists which bear on the foundation wall. Waterproofing should be provided for below-grade masonry.

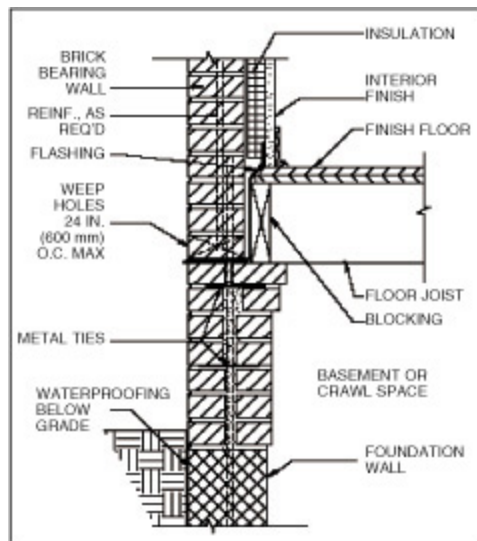

Basement or Crawl Space Foundation
Corbeled Support
Fig. 6

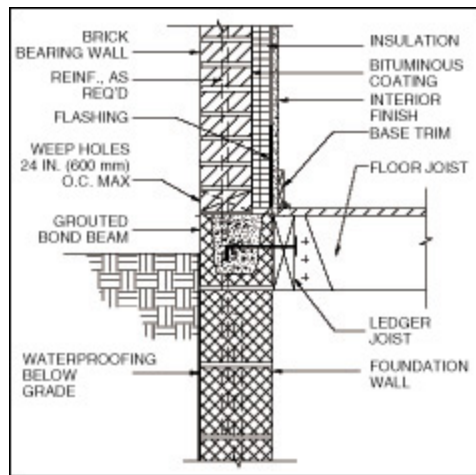

Basement or Crawl Space Foundation Bond Beam Support
Fig. 7

Floors. Floors above the first story may be anchored to the brick bearing walls or be supported on corbeled brickwork. In multi-story construction, anchor bolts cast into a continuous, reinforced, grouted brick bond beam at the floor support level are often used. A continuous wood ledger is bolted into place, and the floor joists are attached to the ledger with joist hangers as shown in Fig. 8. Flashing should extend a minimum of 8 in. (200 mm) above the ledger and at least 3 in. (75 mm) below.

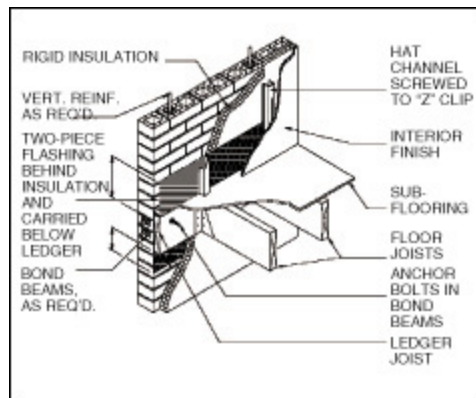

Slab-On-Grade Foundation
Fig. 8

Roof. The roof should be supported directly on top of the bearing wall to minimize eccentric loading. The roof must be anchored on top of the brick bearing wall to resist uplift forces on the roof. A wood plate is attached to the top of the wall using anchor bolts embedded in a bond beam or masonry below. A reinforced concrete bond beam or a reinforced and grouted brick bond beam may be used, as illustrated in Fig. 9. In this case, the anchor bolts should extend a minimum of 12 in. (300 mm) into the grouted cells in the wall below and terminate with a standard hook. One alternative, for use in unreinforced bearing walls, is to thread anchor bolts through the core holes of the solid units and attach the bolts to a steel plate embedded in the masonry, as shown in Fig. 10.

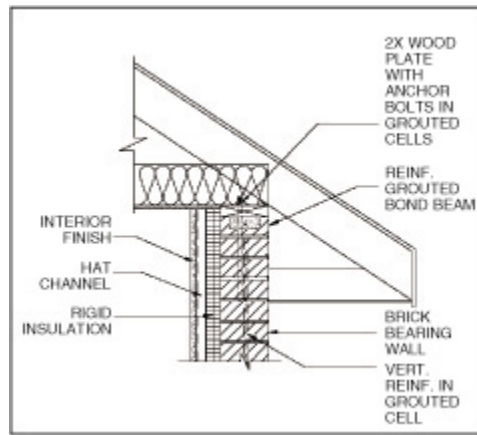

Slab-On-Grade Foundation
Fig. 9

Window and Door Openings

Masonry over openings for windows and doors may be supported by loose steel lintels, reinforced brick masonry lintels or brick masonry arches. The design of steel lintels is covered by Technical Notes 31B. When steel lintels are used, flashing and weep holes should be provided over the lintel as shown in Fig. 11. Alternately, loadbearing brick masonry can be self-supporting over many wall opening. Horizontally reinforced brick masonry lintels are one option. Design of reinforced brick lintels should be in accordance with the MSJC Code or other approved masonry standard.

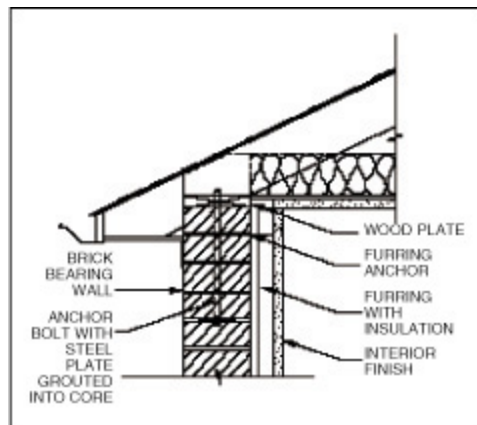

Roof Connection
Fig. 10

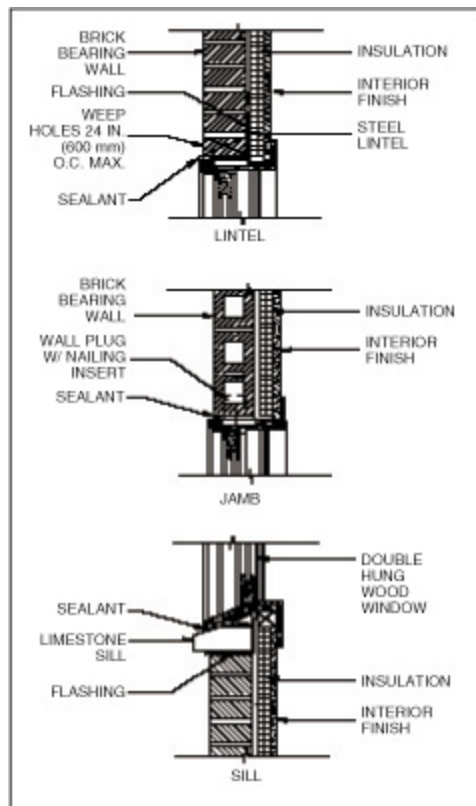

Window Detail With Steel Lintel
Fig. 11

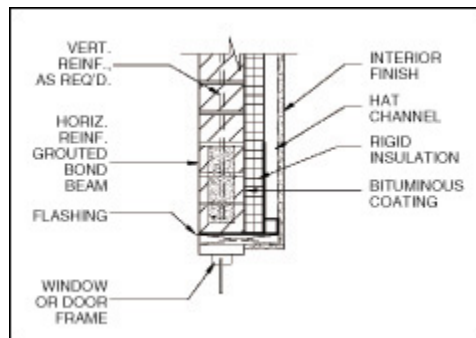

Brick Bond Beam Lintel
Fig. 12b

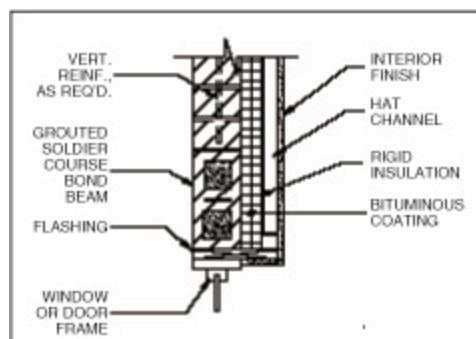

Soldier Course Lintel
Fig. 12a

Reinforcement may be incorporated into voids in a soldier course of brick or in a bond beam, as illustrated in Figs. 12a and 12b, respectively. Figure 13 provides required steel reinforcement for solidly grouted bond beam lintels base on the MSJC Code. Required reinforcement is determined by the total uniform dead and live loads on the lintel and the span of the opening. Figure 13 is applicable to hollow or solid units of 5 to 6 in. (125 to 150 mm) in nominal width. Lintels made of hollow units are assumed to be grouted over their entire height, ht. Generally, for loads greater than

400 lb/ft (6 kN/m), the maximum span length is limited by shear strength of the lintel. Spans may be increased if shear reinforcement is provided in the lintel. Reinforced brick lintels should be shored for a minimum of seven day after construction. Openings can also be spanned by reinforced or unreinforced brick masonry arches. Consult the Technical Notes 31 Series for guidance on the structural design of brick masonry arches.

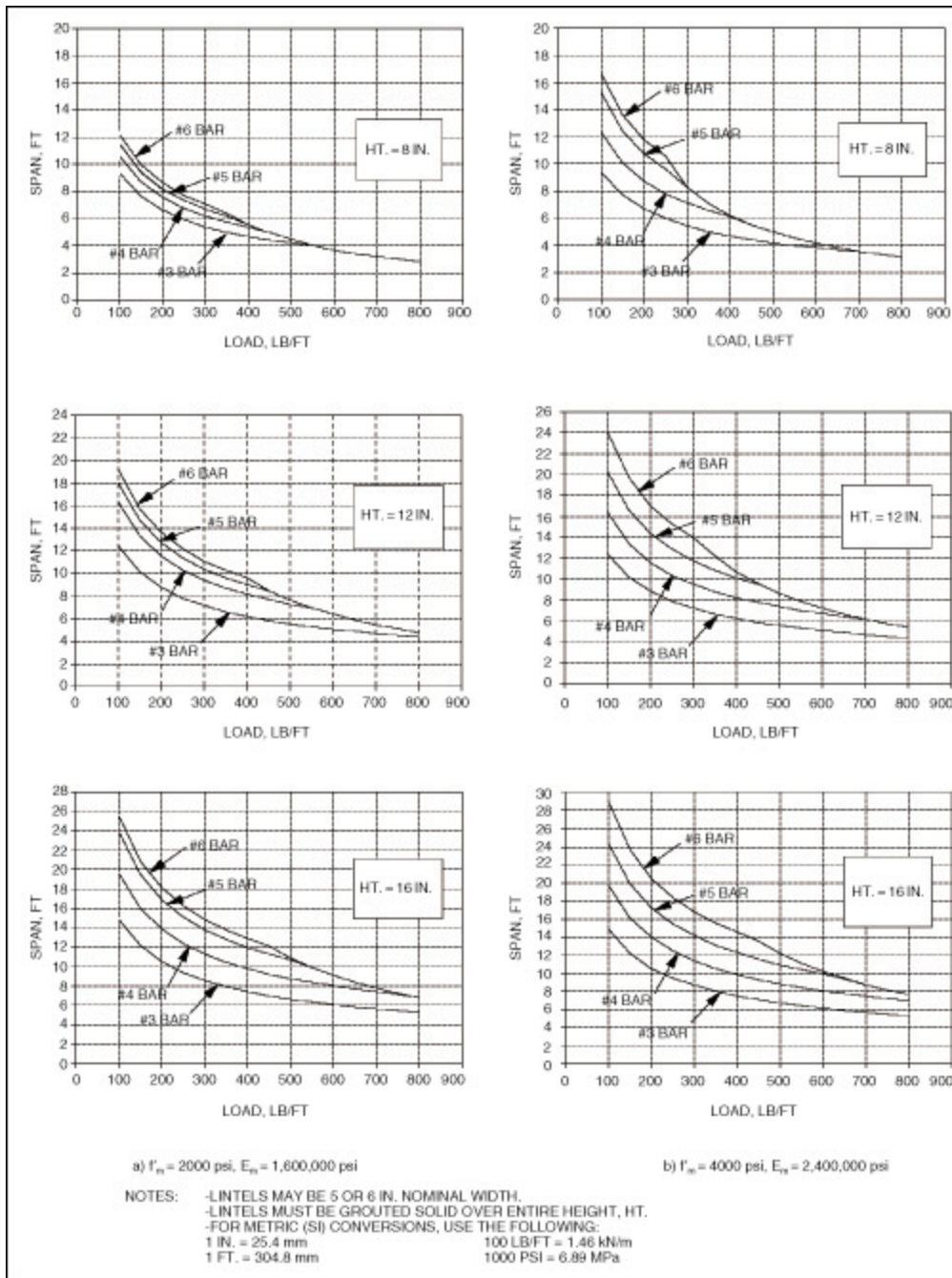

Reinforcement for Brick Bond Beam Lintels
Fig. 13

Flashing and Weep Holes

For best performance, a drainage cavity with flashing and weep holes should be incorporated in the single wythe bearing wall system. The most common method to form a drainage cavity behind the brick wythe is to space the rigid board insulation a minimum of 1/2 in. (13 mm) from the inside face of the brick wythe using furring strips or other spacers. The interior finish is then attached directly over the insulation. Any materials in direct contact with the brick wythe should be rot and corrosion resistant for long-term durability. Alternately, rigid board insulation can be adhered to the brick wythe, and light-gage (non-bearing) metal stud framing can be attached to floor and ceiling joists with no direct contact with the brick wythe. This forms a cavity between the insulation and interior finish which can be flashed similar to that in brick veneer wall systems. A minimum 1/2 in. (13 mm)

cavity is adequate for this wall system because the insulation and finishes are installed after the masonry is completed. Any voids in the mortar should be filled, and any mortar protrusions should be removed to provide a clear, open cavity. Flashing should be placed at the base of the cavity and at all interruptions in the wall, such as over window and door openings. The effect of flashing placement should be considered in the structural design. Splices in flashing must be sealed and discontinuous flashing must have end dams.

Flashing should be turned up a minimum of 8 in. (200 mm) and attached with adhesive to the inside surface of the rigid board insulation or outside surface of the gypsum board, or nailed or stapled to furring strips. The flashing should extend past or be cut flush with the exterior face of the brickwork. If the brick bearing wall is reinforced, the through-wall flashing at the base of the wall will be punctured by vertical reinforcing bars. Flashing must be sealed around all reinforcement with mastic at these locations. Suitable flashing materials are discussed in Technical Notes 7A Revised.

Weep holes should be placed directly above all flashing locations. Weep holes should be located above grade and spaced a maximum of 24 in. (600 mm) on center when using open head joints or brick vents, or 16 in. (400 mm) on center when using wicks or plastic tubes. Open head joint weep holes are preferred over rope wicks or tubes. Vents, copper screening or stainless steel wool can be placed in open head joint weep holes to prevent insects and rain from entering. If the brick bearing wall is treated with a clear water repellent, brick vents in head joints at the base and top of each story are recommended.

Insulation and Finishes

The attachment of insulation and interior finishes may be accomplished in several ways. One method is to attach treated wood or plastic furring strips to wall plugs inserted into mortar joints as shown in Fig. 14, at the top, bottom and mid-height of the wall. Rigid board insulation may be installed between furring strips or over them to form a cavity for drainage. Gypsum board or other interior finish is then placed over the insulation. Another option involves the use of a special "Z" clip. The clip is attached to the brick wythe at 16 or 24 in. (400 or 600 mm) o.c. horizontally or vertically. The leg of the clip extends beyond the rigid board insulation, and special hat channels (so-called because of their shape) are screwed onto the clip, as shown in Fig. 15. The interior finish is then screwed to the hat channels to finish the wall. A third alternative is light-gage (non-bearing) metal stud framing. The framing is used to form a drainage cavity and to apply insulation and/or finishes in a manner similar to that in brick veneer wall systems. Light-gage metal framing is installed by attaching a track to the floor and ceiling joists at the desired distance from the brick wythe. Rigid board insulation may be placed between the metal framing and brick bearing wall, or insulation may be placed between studs. The framing provides a level surface for applying the interior gypsum board or other interior finish. The framing does not provide support for the brick bearing walls. This permits a substantial reduction in the size of the metal framing members. One and one-half inch (40 mm) studs are often used.

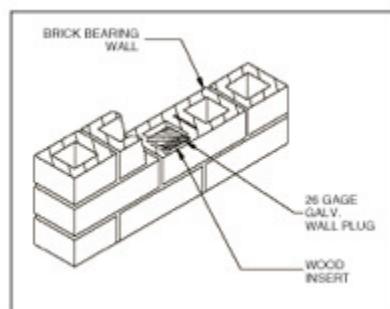

Wall Plug Nailing Insert
Fig. 14

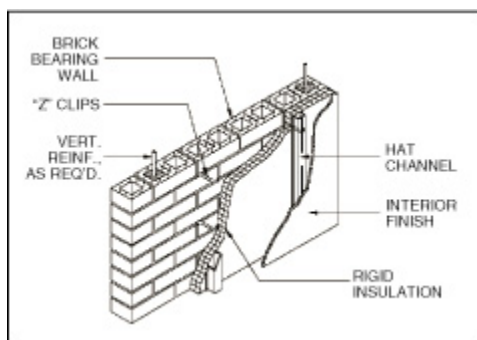

"Z" Clip Installation
Fig. 15

Construction Considerations

Quality Control

The quality of construction of a brick bearing wall is important for several reasons. The masonry wall is the primary structural system for the building and must meet the minimum strength necessary for adequate performance. Without quality construction, the expected strength of the masonry may not be achieved. Good workmanship is also important in resisting water penetration. In a single wythe wall, the masonry is the primary barrier to water penetration, and good workmanship directly affects the water penetration resistance of the masonry.

To ensure quality construction, the MSJC Code and Specifications contain several provisions regarding materials testing, inspection of masonry and workmanship. Brick units and mortar may have to be tested to verify compliance with applicable standards. Verification of assembly compressive strength may be determined by preconstruction testing of brick masonry prisms constructed from the same brick and mortar to be used on the project. Alternately, assembly compressive strength may be verified by the conservative unit strength method which requires knowledge of the brick unit compressive strength and mortar Type to estimate the masonry assemblage's strength. Inspection of the masonry during construction is required by the MSJC Code, and limits on the dimensional tolerances of masonry elements ensure expected structural performance.

In reinforced brick masonry, maintaining clear grout spaces during construction and proper location of reinforcement are important. The cells of hollow brick intended to receive reinforcing bars and grout should be free of mortar protrusions and debris. One method of keeping the cells of hollow brick clean is to insert sponges into the cells to be grouted at the beginning of construction. The sponges are pulled upward by a handle, wire or string as construction progresses, leaving clean cells ready for grouting, as shown in Fig. 16. Another method, if sponges are not used, is to provide cleanout openings at the base of the wall at all grout locations. The cleanouts allow the mortar protrusions to be scraped off after construction and the debris removed at the wall base. See Fig. 17. The cleanouts are sealed prior to commencing with grouting. One method of closing cleanouts in hollow brick is to bevel cut the section of the face shell to be removed. When replaced, the cut piece is held in position by pressure from the grout. Cleanouts are seldom used in single wythe construction except with large cell hollow brick or at pilaster locations. For further information on grouting brick masonry walls, see Technical Notes 17C and the MSJC Code and Specifications.

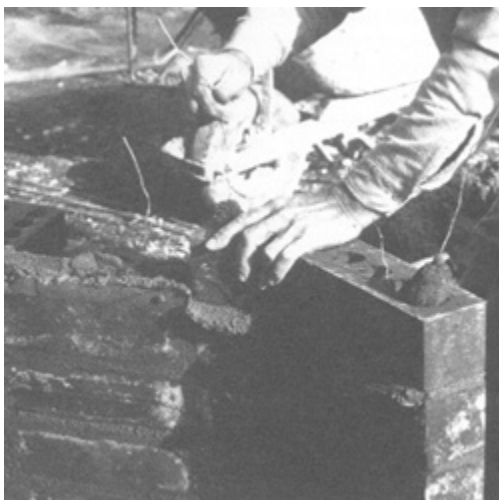

**Sponges In Cells To Be Grouted
Fig. 16**



**Grout Cleanouts
Fig. 17**

To resist water penetration, full head joints should be used with solid and hollow units, and full bed joints are recommended with solid units. Proper installation of flashing and weep holes and other moisture control measures will control water which does penetrate the brick masonry wythe.

Sequence of Work

In a loadbearing wall system, brick masonry is the primary structural element. The masonry work may begin as soon as the foundation is complete and properly cured. Bearing walls should be braced during construction until lateral support is provided by the floors and roof. Once one story height is laid, construction of the floor or roof systems follow, possibly serving as a work platform for the remaining masonry work. The fasteners necessary for attachment of the cabinets, insulation and interior finishes should be incorporated during the construction of the masonry. Interior frame walls may be built simultaneously with the exterior loadbearing brick walls once the floor has been constructed, at the builder's discretion.

Brick bearing walls should attain sufficient strength before any loads are applied. The curing conditions will affect the rate of strength gain of loadbearing masonry. If sufficient moisture is maintained, the masonry walls should cure a minimum of three days before supporting floor or roof loads. Reinforced brick masonry beams require curing periods of at least seven days. Poor curing conditions, such as exposure to cold temperatures, may require longer curing times. Once the brick bearing walls are cured, the floors and roof may be attached. The windows, doors, plumbing,

electrical and heating systems, insulation and interior finishes can be installed as soon as the masonry is complete.

SUMMARY

This Technical Notes covers the design and detailing of single wythe bearing walls. Selection of materials and methods of reinforcing and finishing brick bearing walls are discussed. The information provided illustrates a few of the many options available for a single wythe brick bearing wall system. Design and construction considerations presented are equally applicable to residential and commercial construction. Any design should be completed in accordance with the MSJC Code and Specifications and applicable model building and energy codes.

The information and suggestions contained in this Technical Notes are based on the available data and the experience of the engineering staff of the Brick Institute of America. The information contained herein must be used in conjunction with good technical judgement and a basic understanding of the properties of brick masonry. Final decisions on the use of the information contained in this Technical Notes are not within the purview of the Brick Institute of America and must rest with the project architect, engineer and owner.

REFERENCES

1. "Brick Masonry Material Properties," Technical Notes on Brick Construction 3A, Brick Institute of America, Reston, VA, December 1992.
2. "Brick Masonry Section Properties," Technical Notes on Brick Construction 3B, Brick Institute of America, Reston, VA, May 1993.
3. "Building Code Requirements for Masonry Structures ACI 530/ASCE 5 and Specifications for Masonry Structures ACI 530.1/ASCE 6," Technical Notes on Brick Construction 3, Brick Institute of America, Reston, VA, February 1990.
4. Building Code Requirements for Masonry Structures and Commentary (ACI 530/ASCE 5/TMS 402) and Specifications for Masonry Structures and Commentary (ACI 530.1/ASCE 6/TMS 602), American Concrete Institute, Detroit, MI, 1992.
5. One-and Two-Family Dwelling Code, Council of American Building Officials (CABO), Falls Church, VA, 1992.
6. "Structural Design of Brick Masonry Arches," Technical Notes on Brick Construction 31A Revised, Brick Institute of America, Reston, VA, July 1986.
7. "Structural Steel Lintels," Technical Notes on Brick Construction 31B Revised, Brick Institute of America, Reston, VA, May 1987.